

1 2 3 4 6 7

A

A

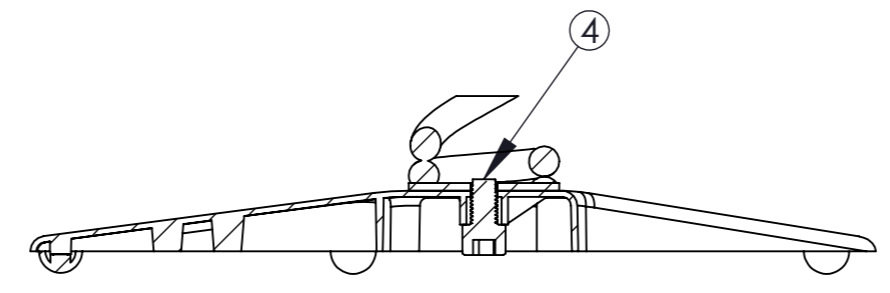
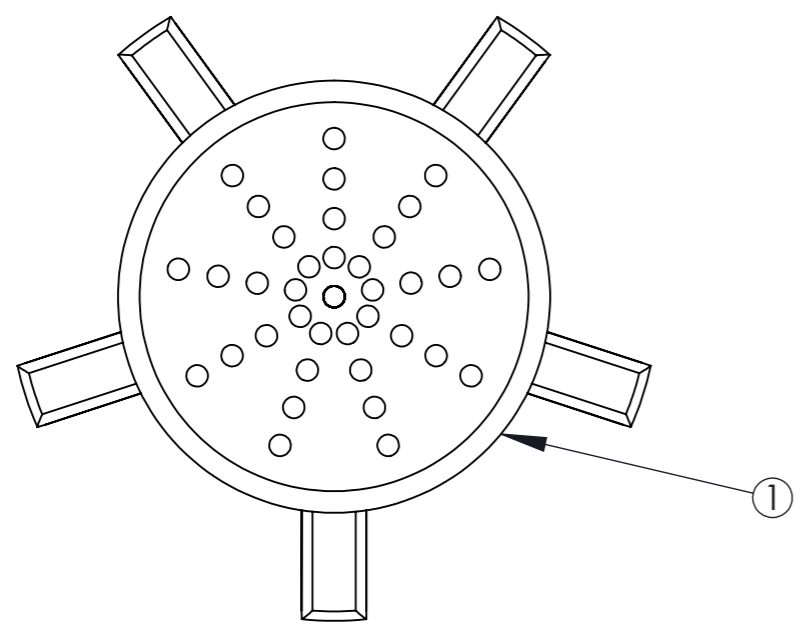

SECTION D-D  
SCALE 1 : 5

B

B

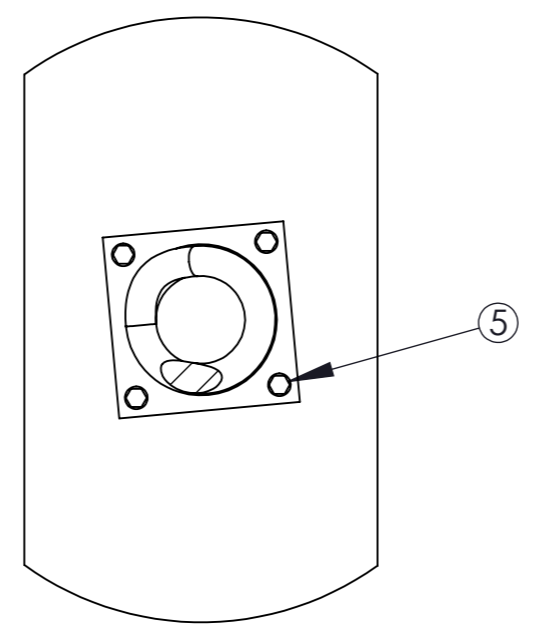
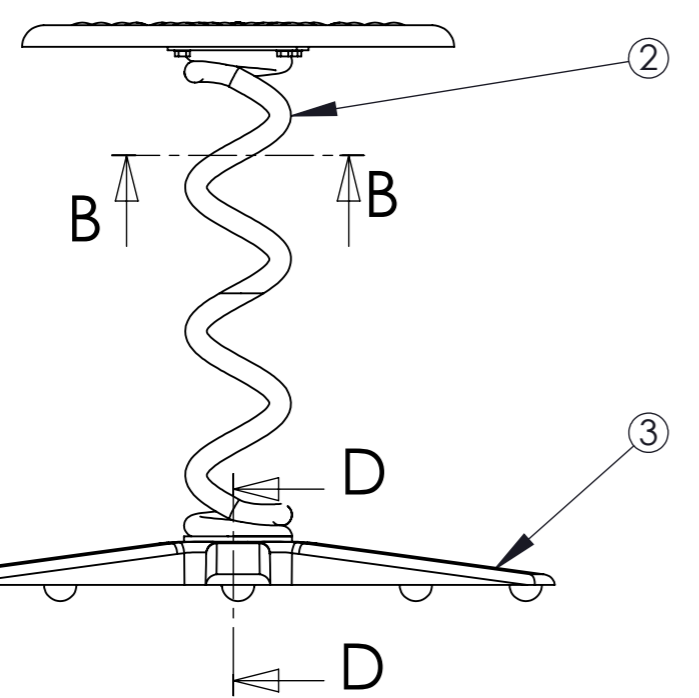

SECTION B-B  
SCALE 1 : 5

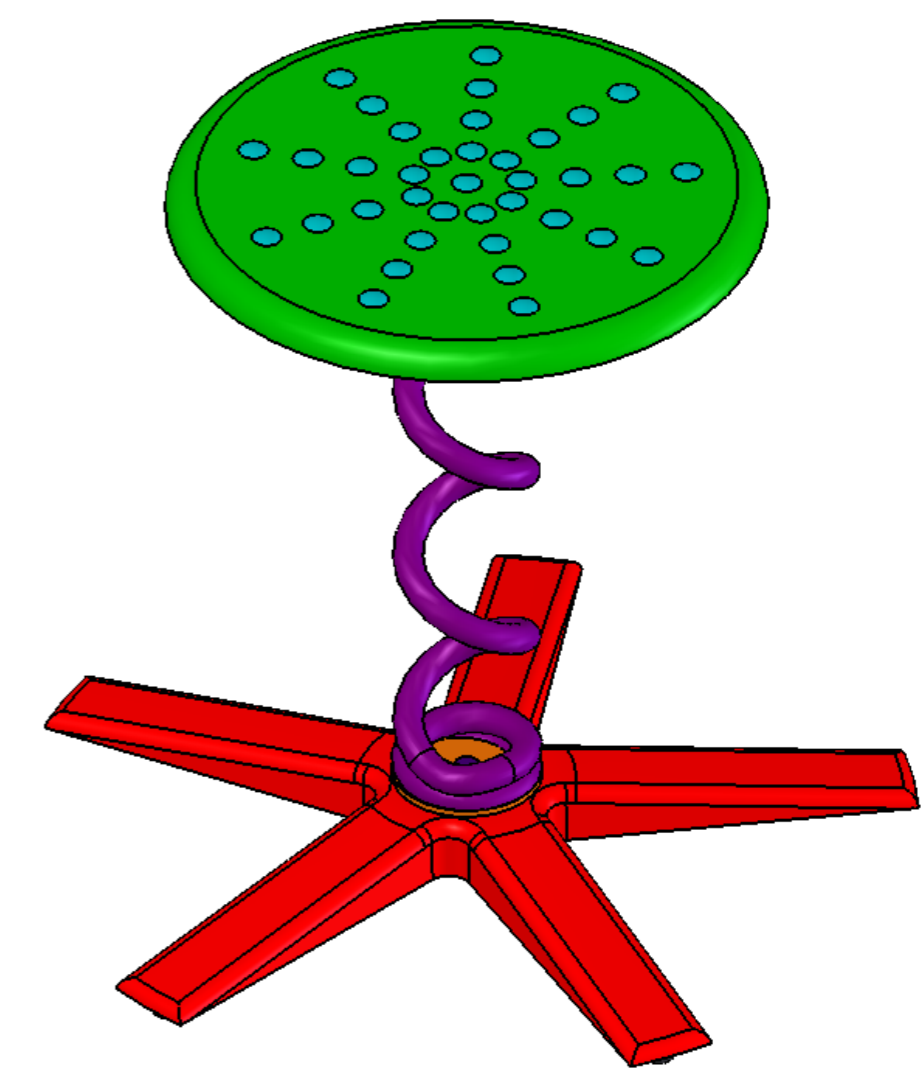

C

C

D

D

THIS DRAWING SHOULD BE CONSIDERED WITH THE BOM AND THE 3D FILE (IF SUPPLIED)

MATERIAL: <b>NIL</b>	UNLESS OTHERWISE SPECIFIED	DATE 15-JAN-2008	EMMA'S FITNESS		
	DIMENSIONS ARE IN MILLIMETERS				
FINISH: <b>NIL</b>	TOLERANCES		REVISION 1	TITLE: <b>EXER-SEAT</b>	
	DECIMALS: X.X ± 0.20 X.XX ± 0.10				
	FRACTIONS ± 1/32 ANGULAR: ± 0°30' FINISH: 1.6				
DO NOT SCALE THIS DRAWING					

1 2 3 4 6 7